

# Mattress Foundation

## Assembly Instructions

### Foundation Size

- Twin
- Twin XL
- Full
- Full XL
- Queen
- King
- Cal. King

### Material & Hardware Included

**A** end rails x 2

**B** side rails x 2

**C** Center Support Rail

Twin & Twin XL x 0

Full & Queen x 1

King & Cal. King x 2

**D** slats x 13, or 14  
(depending on the model)

**E** foundation cover x 1

**F** carriage bolts x 12 or 16  
(depending on the model)

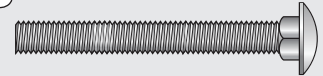

**G** flange nuts x 12 or 16  
(depending on the model)



**H** wood screws x 42 or 56  
(depending on the model)

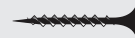

**I** 1/2" wrench x 1

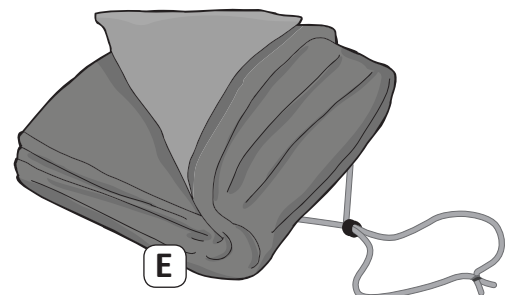
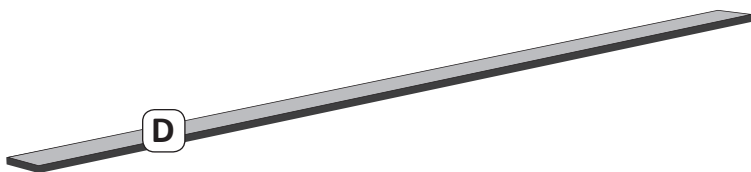
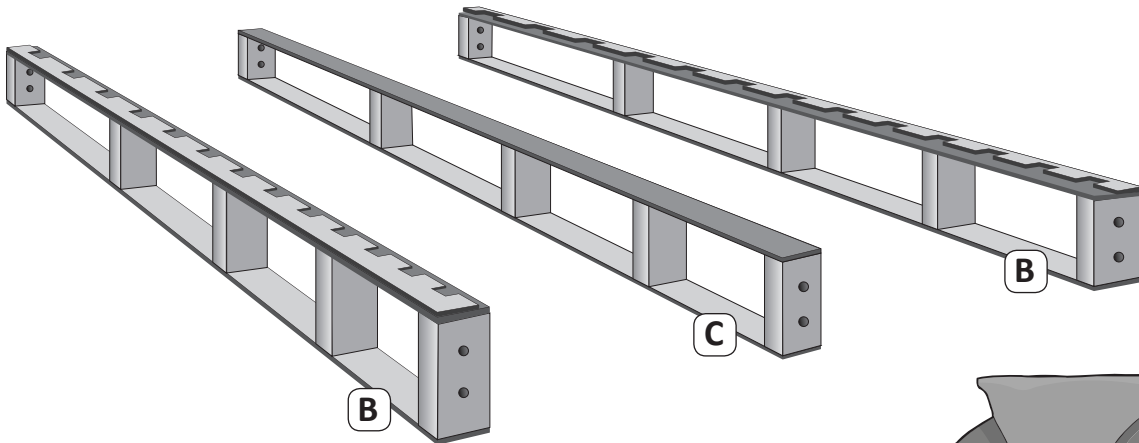
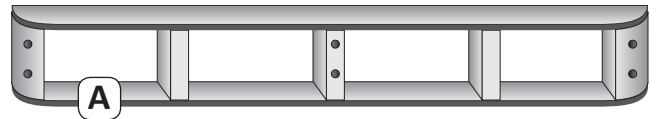
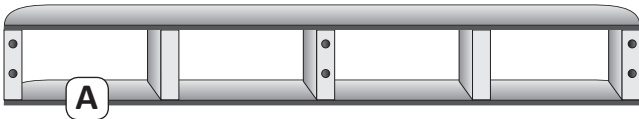
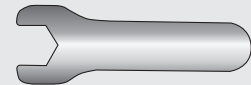

## Step 1

Place side and center rails on floor parallel to each other.

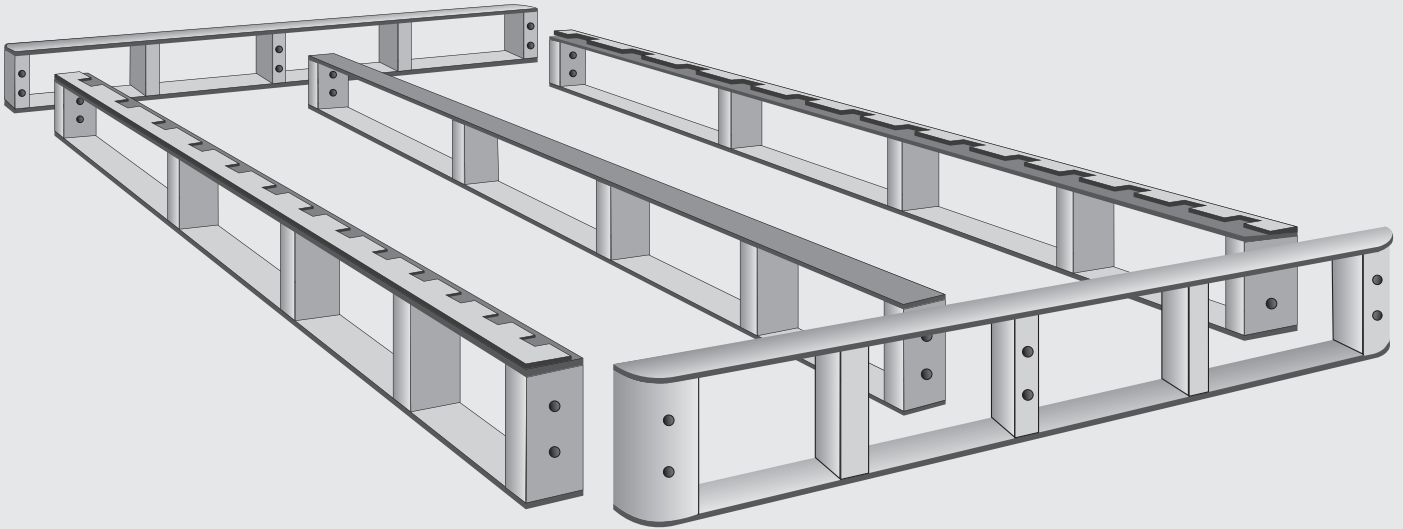

## Step 2

Fasten one end rail to sides and center (if your kit has a center rail) using bolts and flange nuts. **Hand tighten only.**

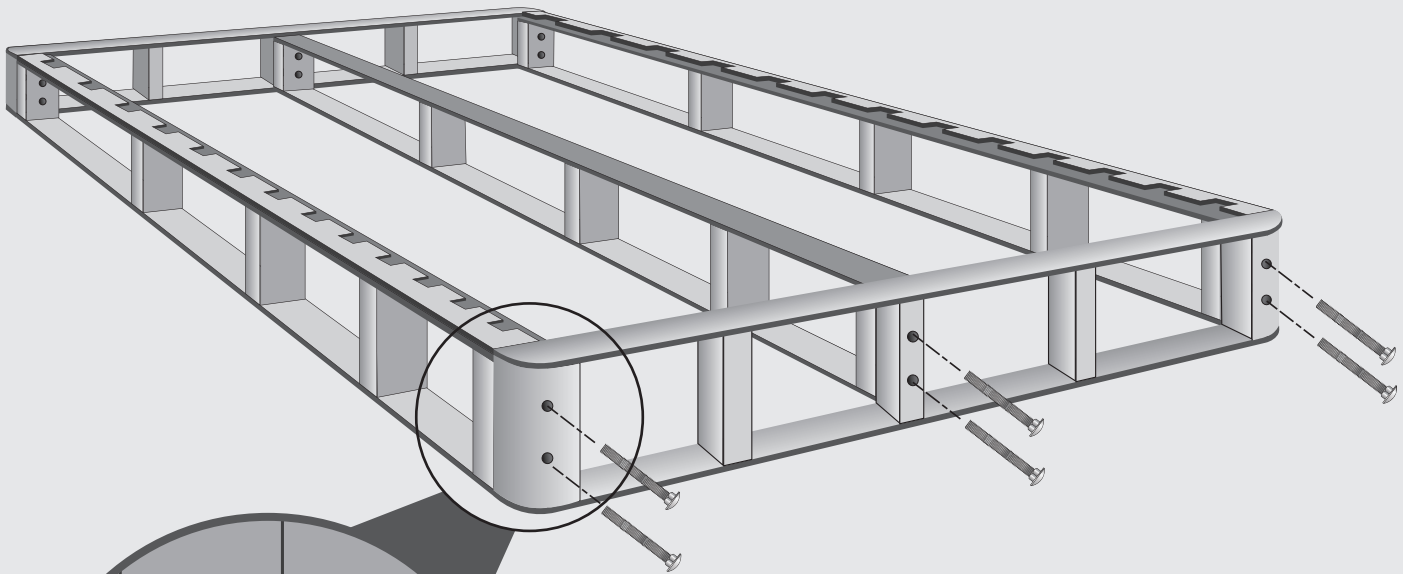

Repeat step 2 at other end of foundation. When completely assembled tighten all flange nuts with wrench.

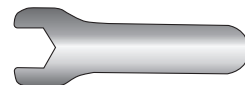

### Step 3

Place the slats in the notches on the sides of the foundation.

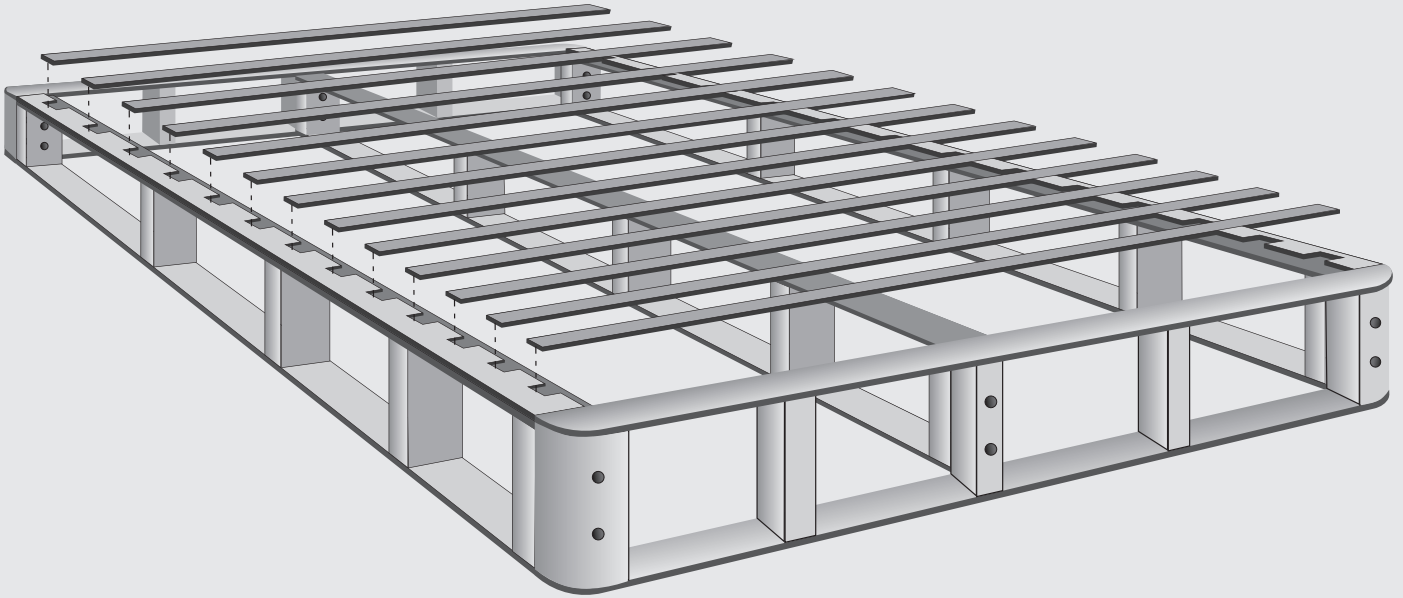

### Step 4

Screw down the slats starting at the ends and then the center.  
*(Screwdriver not included.)*

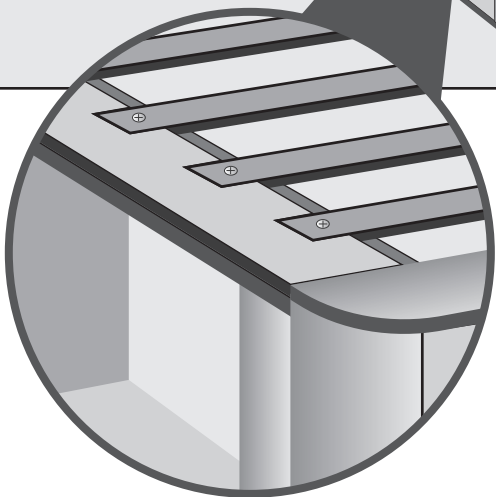
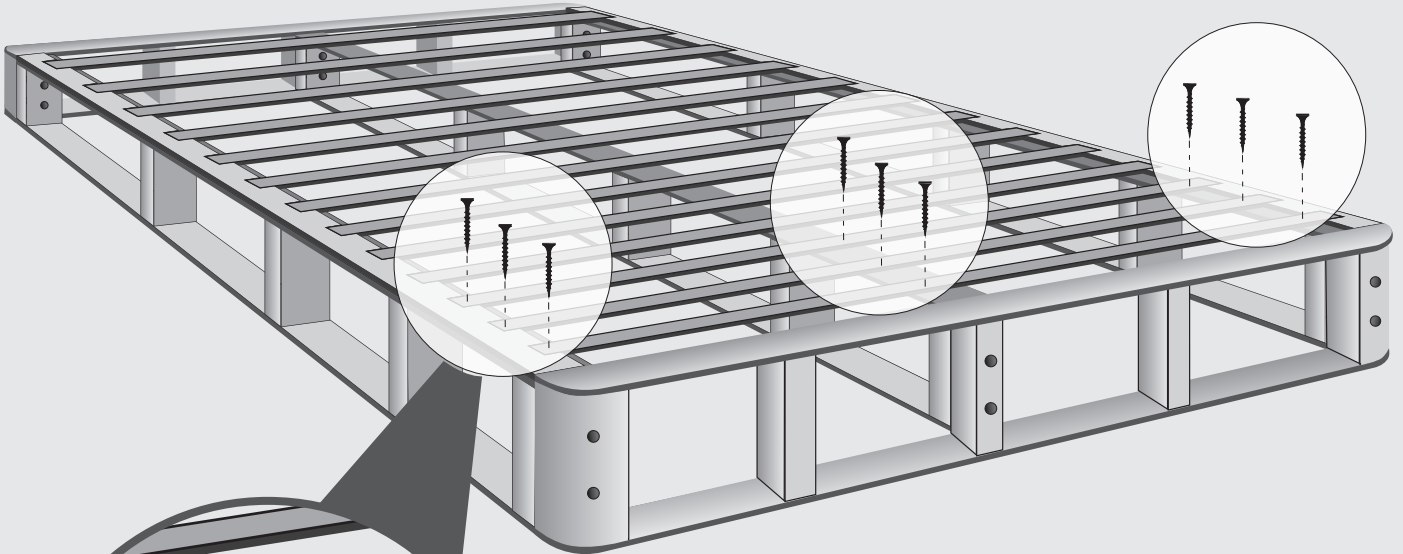

### Step 5

Unfold the cover and place on the foundation. Get each corner started a little then pull down snugly on all sides.

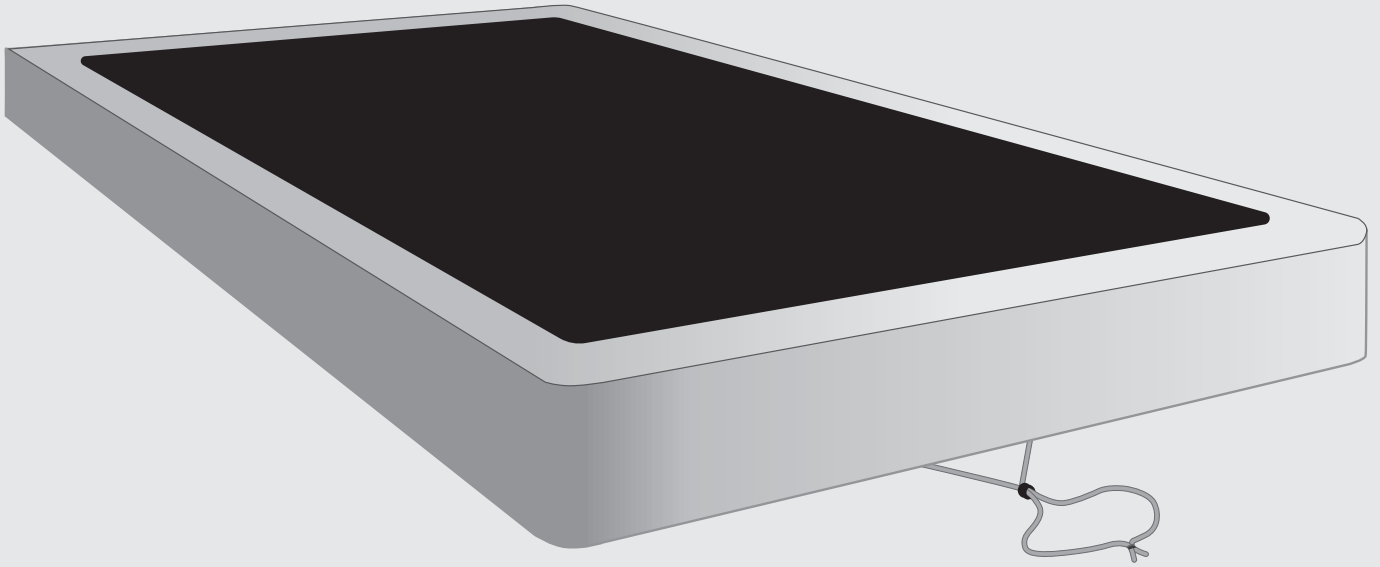

### Step 6

Pull the drawstring to tighten the cover and slide the locking ball in place.

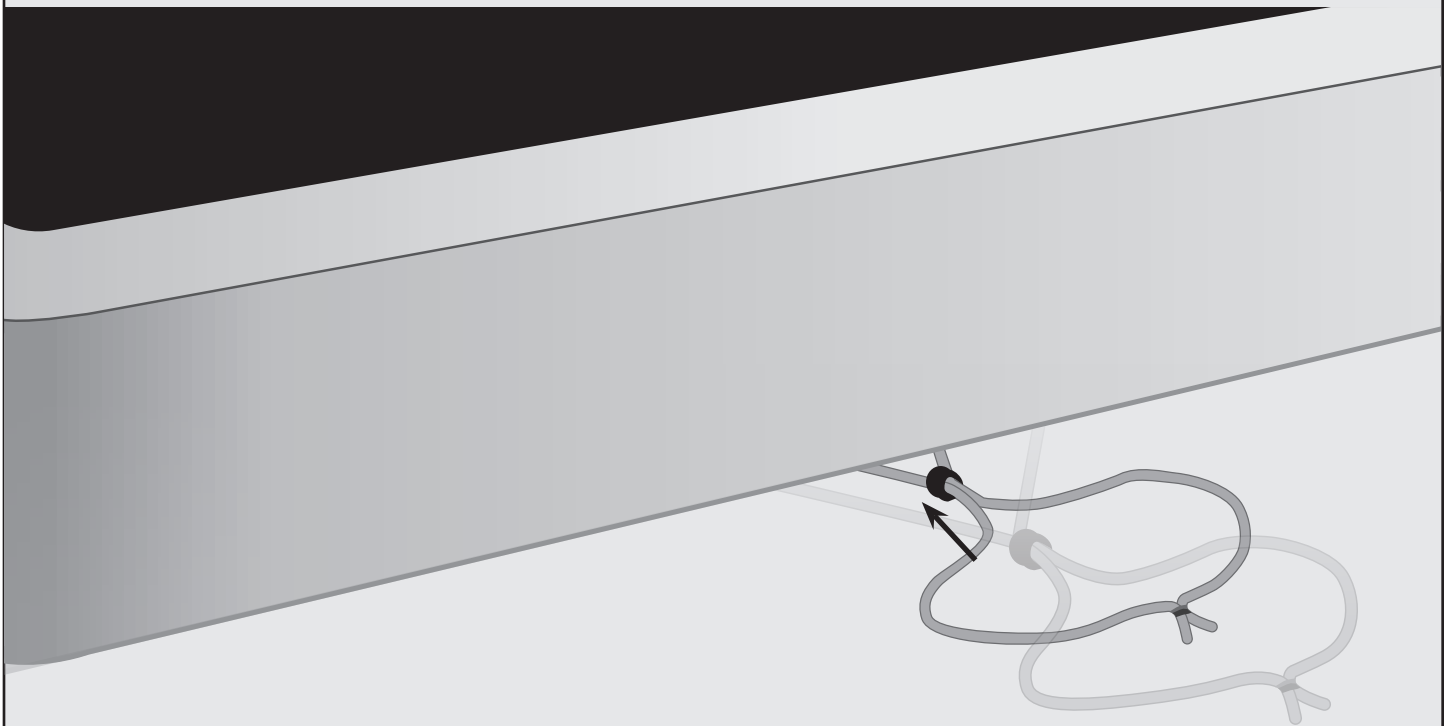

## Questions?

We want to offer your support if you need help in putting your new product together. If you have any questions or concerns regarding your new product, please contact our customer service at:  
**[Info@nscmedical.com](mailto:Info@nscmedical.com)**



PATENT #8167012

